

The Componon 2.8/28 is a 28 mm focal length, macro lens with 30 mm image circle (for F/# 2.8 only for 2/3" sensor recommended) for large format sensors and short working distance. This macro lens is developed and corrected for the close-up range of 1:20 to 1:1 and can also be used in reverse position depending, on the field of vision and pixel size with the symmetrical V-Mount interface without additional accessories.

The modular system with wide-ranging accessories such as helical focus barrel (Unifoc 7 and 12), extension tubes, and adapters for various cameras, can be used for all kind of sophisticated applications from OLED inspection to food processing control. This, the fast F/# of 2.8 and low longitudinal and lateral chromatic aberration, as well as extremely low distortion all combined make these lens unique.

Vibration insensitivity for stable imaging performance even when the lens used in harsh industrial environmental, as common in food processing control and web inspection systems. The Unifoc Series offers more macro lenses with 35 mm, 40 mm, 45 mm, 50 mm, 60 mm, 80 mm, 90 mm, 100 mm focal length and a line scan lens series plus a enlarging lens series for Unifoc 58 and 76 helicoid focus barrels.



Componon 2.8/28

## Key features

- Large Format
- Short working distance
- Modular: Unifoc 7 and 12 focus helical barrels, extension tubes, various camera adapters
- Possibility to be used in retro position
- Vibration insensitivity for stable imaging performance

## Applications

- OLED inspection
- Web inspection
- Medical applications
- Laser triangulation
- Quality control

Name	Componon 2.8/28
Type	-0001
Focal Length [mm]	28
Magnification	-0.5
Image circle [mm]	30
Resolution [ $\mu\text{m}$ ]	3.65
F/# range	2.8 ... 16
NA	0.18
Interface	V38-Mount
Working distance [mm]	$\infty$ - 77
AoV [°]	54
Focus control	manual
Transmission [nm]	400 - 1000
Filter thread [mm]	M37 x 0.75
Dimensions L x D [mm]	33.2 x 47.0

Name	Componon 2.8/28
Weight [g]	105
Storage temperature [°C]	-25 ... +70
$f'_{\text{eff}}$ [mm]	29.29
$S_F$ [mm]	-16.31
$S'_F$ [mm]	20.82
HH' [mm]	-2.94
$\beta'_p$	1.049
$S_{EP}$ [mm]	11.62
$S'_{AP}$ [mm]	-9.90
$\Sigma d$ [mm]	18.52
ID	14794

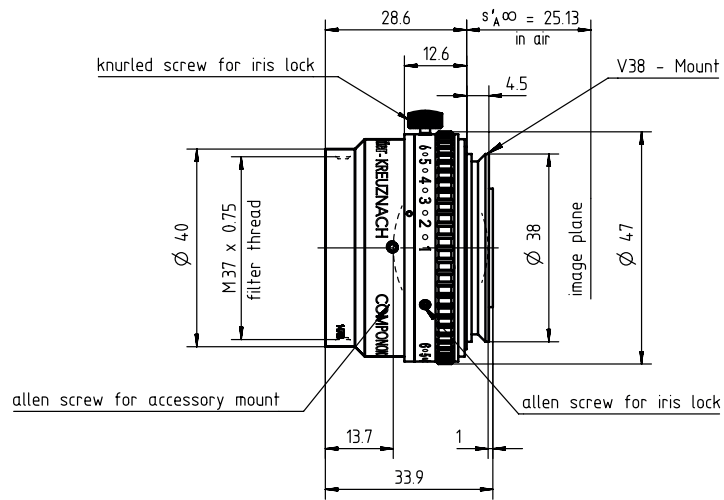

### Distortion vs. Image Height

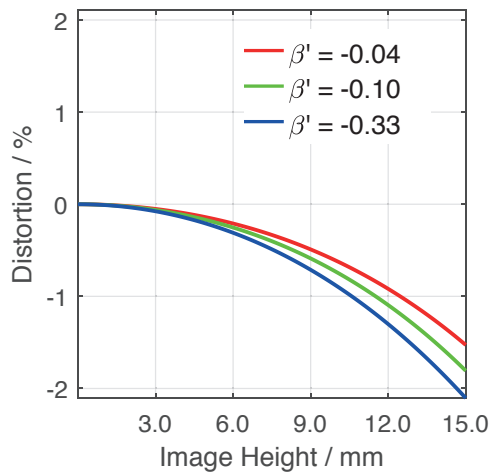

### Transmittance vs. Wavelength

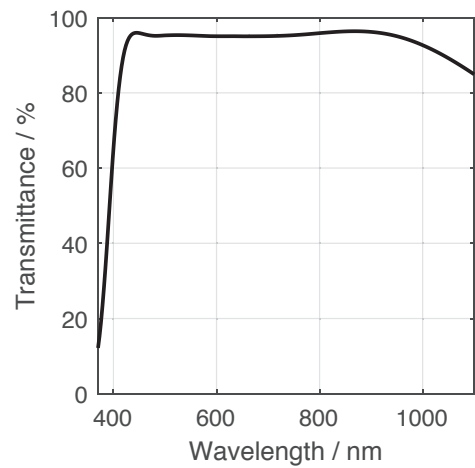

### Relative Illumination vs. Image Height

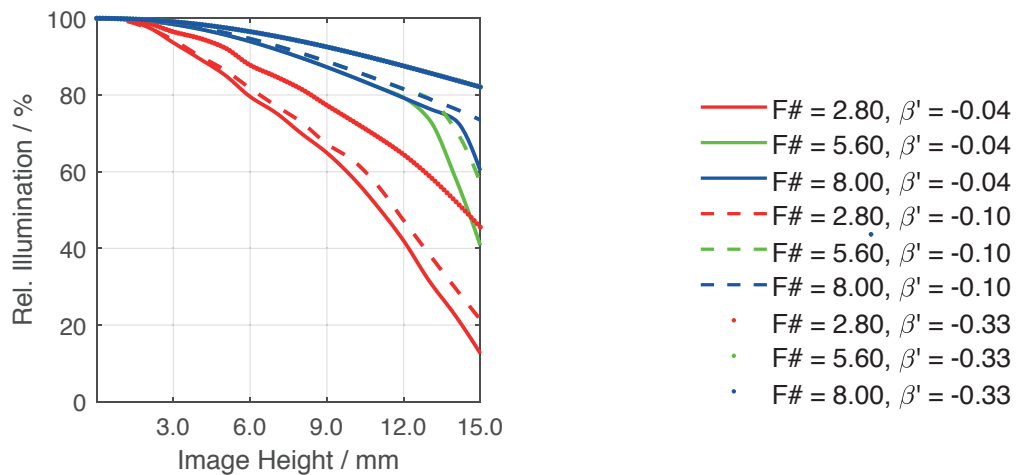

Spectrum Name	VIS					
Wavelengths [nm]	425	475	525	575	625	675
Weights	8	16	23	22	19	13

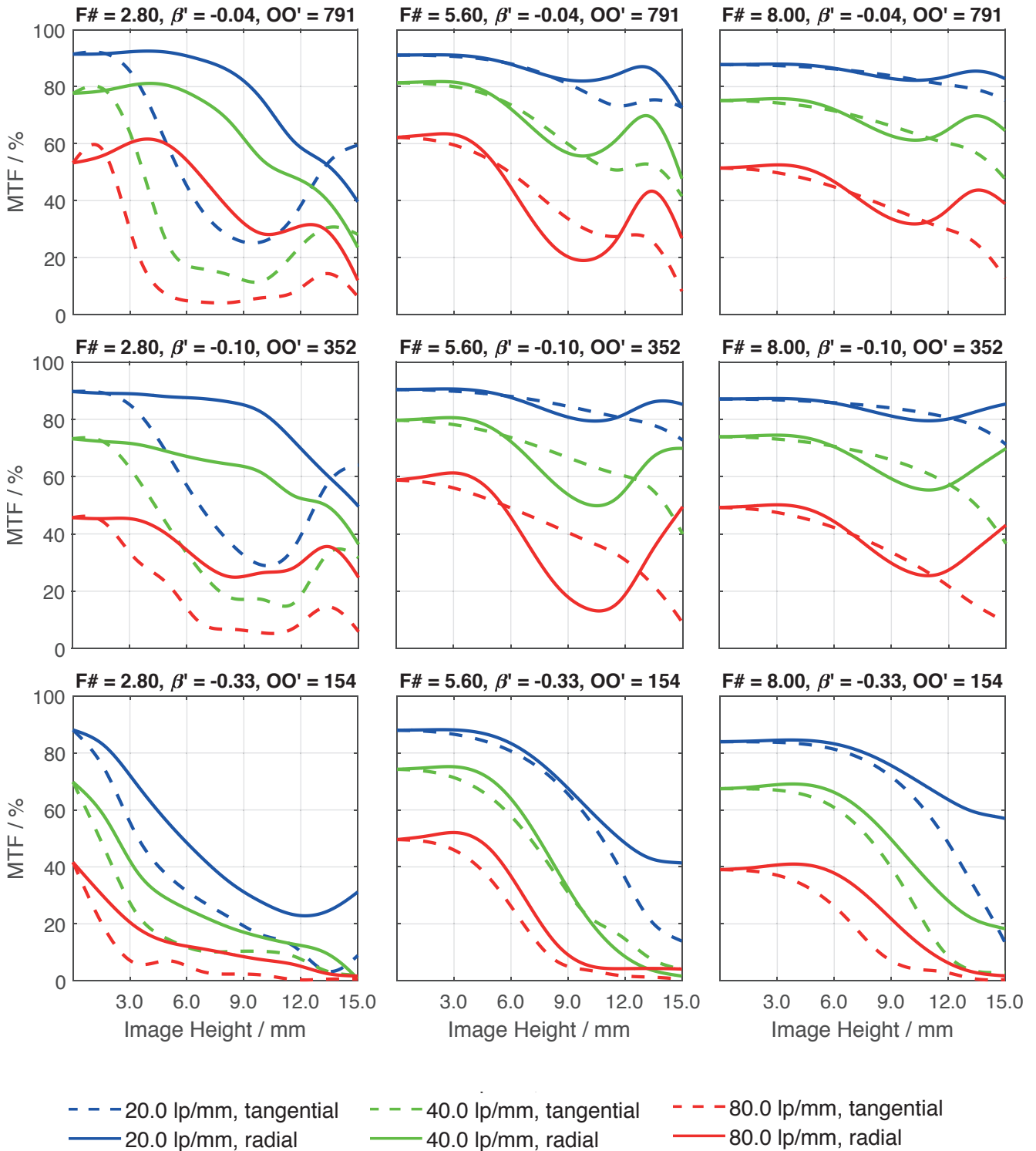

Accessories	Mount	Length	ID
Makro	UNIFOC 12	-	11726
	UNIFOC 7	-	1001041
	UNIFOC 7 (M58 x 0.75)	-	1054532
Ext. Tube	V38 / V38	6 mm	20176
	V38 / V38	8 mm	20177
	V38 / V38	10 mm	20178
	V38 / V38	25 mm	20179
	V38 / V38	50 mm	20154
	V38 / V38	75 mm	20155
Adapter	V38 / C-Mount	-	20052
	V38 / C-Mount Hub V38 / C-Mount	19.2 - 24.2 mm	1011634
	V38 / Leica (M39 x 26 Gg.)	-	20054
	V38 / T2 (M42 x 0.75)	-	20053
	V38 / M42 x 1	-	20059
	V38 / M42 x 1 - Length 35 mm	-	1001692
	V38 / M58 x 0.75	-	1018385
	V38 / Nikon F-Mount	-	21610

# Get more information

Contact our local offices



## Headquarter Germany

Jos. Schneider Optische Werke GmbH

Ringstraße 132

55543 Bad Kreuznach

☎ +49 671 601 205

✉ [cs@schneiderkreuznach.com](mailto:cs@schneiderkreuznach.com)

[www.schneiderkreuznach.com](http://www.schneiderkreuznach.com)

## Offices Worldwide

### China

☎ +86 755 8832 1170

✉ [shawn.liu@schneider-asiapacific.com](mailto:shawn.liu@schneider-asiapacific.com)

### North America

☎ +1 800 645 7239 (East Coast)

☎ +1 800 228 1254 (West Coast)

✉ [info@schneideroptics.com](mailto:info@schneideroptics.com)

### Singapore

☎ +65 9488 0062

✉ [thongv@schneiderkreuznach.com](mailto:thongv@schneiderkreuznach.com)