

MVL-KF2524M-25MP 1.2" 25mm 25MP FA LENS

KF-P series FA Lens are optimized for machine vision light sources and sensors, with high resolution, excellent image uniformity, high transmittance and good stability. Featured with fixed focal length, manual aperture and compact size, it is suitable for machine vision industry applications.



Key Features

- Ultra high resolution and consistency of image clarity
- 1.2" image Format, bigger aperture, lower distortion, Higher illumination relative
- Achromatic optical system design, Better imaging performance with color camera
- Maintain excellent optical properties at different object distances
- Excellent vibration resistance and stability at high and low temperature performance, optical axis shifting within pixel level
- Multilayer and broadband coating design, compatible with visible and near infrared applications

Distortion

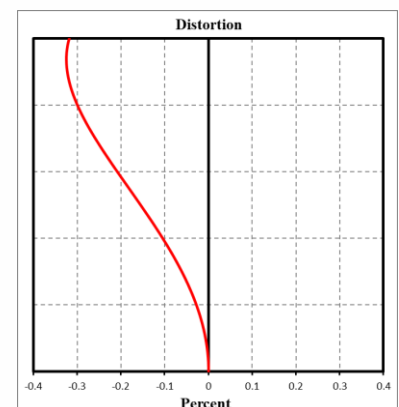

MTF

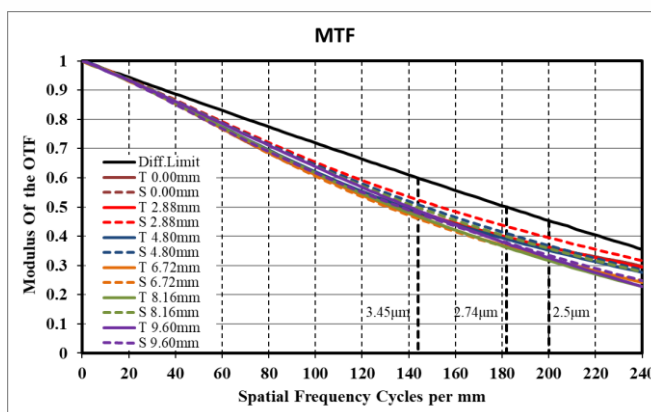

Relative Illumination

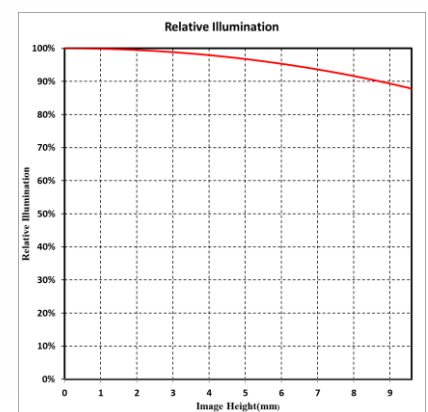

Note: The above curves are the simulate results based on F4, $\beta=-0.082$, WD=300 mm



Specification

Model	MVL-KF2524M-25MP
Parameter	Fixed focal length, Manual iris, 25MP, FA Lens
Performance	
Focal Length	25 mm
F-Number	F2.4 ~ F16
Image Size	Φ19.3 mm(1.2")
Distortion	-0.04%
Minimum Operation Distance	0.15 m
Field of View	D (19.30mm) : 40.80° H (14.60mm) : 31.42° V (12.63mm) : 27.34°
Mechanical	
Iris Control	Manual
Focus Control	Manual
Filter Thread	M37×0.5
Mount	C-Mount
Flange Back Length	17.526 mm
Dimension	Φ40×58.4 mm
Weight	163 g
Temperature	-10 ~ 50°C
General	
Certification	RoHS2.0

Dimension

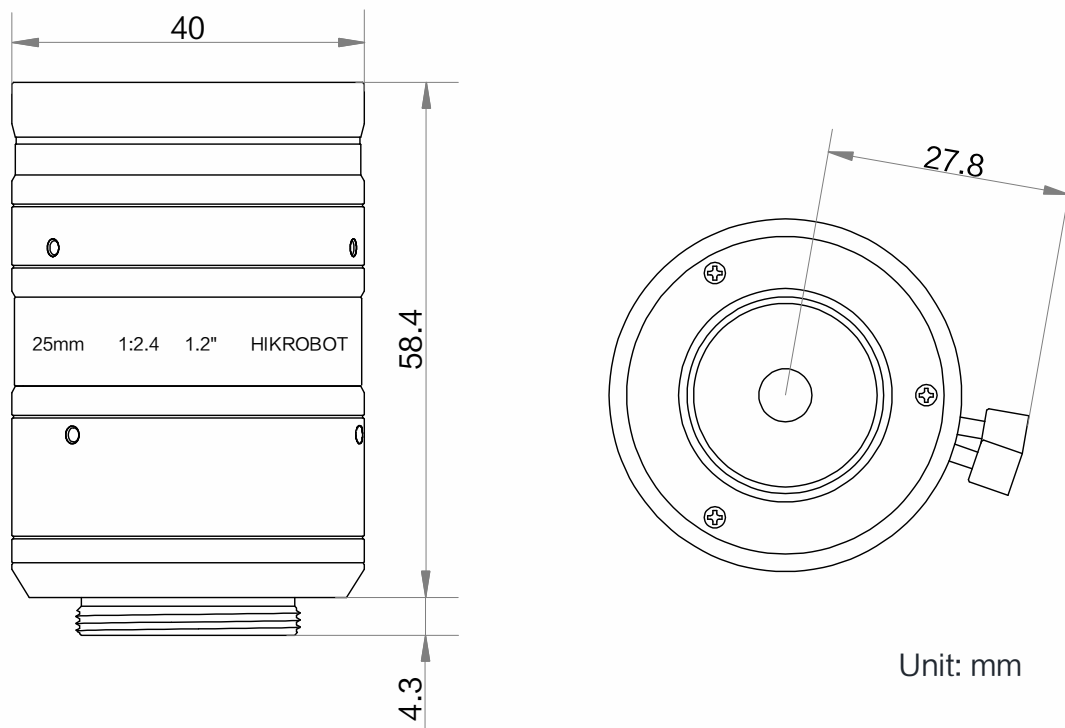

Unit: mm

Field of View

Extension (mm)	Working Distance (mm)		Magnification	Field of View (mm)					
				1.2"		1.1"		2/3"	
				H(14.6mm)	V(12.63mm)	H(14.14mm)	V(10.35mm)	H(8.45mm)	V(7.07mm)
2	near	99.84	-0.242	60.83	52.54	58.89	43.00	35.07	29.32
	far	216.93	-0.111	132.76	114.71	128.54	93.88	76.58	64.03
1	near	120.24	-0.203	72.39	62.55	70.09	51.20	41.77	34.93
	far	344.84	-0.071	207.70	179.54	201.12	146.99	119.92	100.29
0		150	-0.164	89.23	77.13	86.40	63.15	51.53	43.09
		200	-0.123	119.19	103.05	115.42	84.38	68.85	57.59
		250	-0.098	148.96	128.79	144.25	105.47	86.07	71.98
		300	-0.082	178.64	154.46	173.00	126.50	103.23	86.34
		350	-0.070	208.27	180.09	201.69	147.49	120.36	100.67
		400	-0.062	237.87	205.69	230.36	168.46	137.47	114.98
		450	-0.055	267.45	231.27	259.00	189.41	154.57	129.28
		500	-0.049	297.02	256.84	287.64	210.35	171.66	143.58
		550	-0.045	326.58	282.40	316.26	231.29	188.74	157.87
		600	-0.041	356.12	307.95	344.88	252.22	205.82	172.15
		650	-0.038	385.67	333.50	373.49	273.15	222.90	186.44
		700	-0.035	415.21	359.05	402.10	294.07	239.97	200.72
		800	-0.031	474.28	410.13	459.30	335.91	274.12	229.28
		900	-0.028	533.34	461.21	516.50	377.74	308.26	257.83
	1000	-0.025	592.39	512.27	573.69	419.57	342.39	286.38	